

iQ500, free-standing fridge-freezer with freezer at bottom, 203 x 60 cm, Black stainless steel KG39NAXCF



Bottom freezer with hyperFresh Box to keep fruit and vegetables fresh for longer, plus noFrost for no more defrosting.

- ✓ hyperFresh <0°C> – More space for fruit and vegetables. A cold climate for fish and meat.
- ✓ noFrost – Never defrost your freezer again.
- ✓ Metal backwall with multiAirflow: evenly cooled food and drinks on all levels.
- ✓ Home Connect – Control your smart fridge no matter where you are.
- ✓ freezerLight – Brilliant lighting inside your freezer.

Features

Technical Data

Energy Efficiency Class: C
 Average annual energy consumption in kilowatt hour per year (kWh/a): 162 kWh/annum
 Sum of volume of frozen compartments: 103 l
 Sum of volume of chill compartments: 260 l
 Airborne acoustical noise emissions : 35 dB(A) re 1 pW
 Airborne acoustical noise emission class: B
 Built-in / Free-standing: Free-standing
 Door panel options: Not possible
 Height: 2030 mm
 Width of the appliance: 600 mm
 Depth of the product: 665 mm
 Net weight: 73.7 kg
 Fuse protection: 10 A
 Door hinge: Right reversible
 Voltage: 220-240 V
 Frequency: 50 Hz
 Length electrical supply cord: 240 cm
 Number of compressors: 1
 Number of independent cooling systems: 2
 Interior ventilator: No
 Reversible Door Hinge: Yes
 Number of Adjustable Shelves in fridge compartment: 3
 Shelves for Bottles: Yes
 Installation typology: N/A

Included accessories

- 3 x egg tray
- 1 x ice cube tray



**iQ500, free-standing fridge-freezer
with freezer at bottom, 203 x 60 cm,
Black stainless steel
KG39NAXCF**

Features

Performance and consumption

- EU19_EEK_D: C
- Total Volume : 363 l
- Net Fridge Volume : 260 l
- Net Freezer Volume : 103 l
- Freezing capacity 24h: 10 kg
- Annual Energy Consumption: EU19_Annual energy cons rd_D: 162 kWh/a
- Climate Class: SN-T
- Fast Freeze Facility
- Noise Level : 35 dB , EU19_Noise emission class_D: B
- Temperature rise time : 15 H

Design and Styling

- Doors black inox-antifingerprint, side panels cast iron
- Integrated vertical handle
- Metal backwall with multi airflow
- LED with Soft Start in fridge section

Convenience & Safety

- Total NoFrost - never defrost again
- Connected appliance: Remote Monitoring and Control
- Home Connect enabled via WLAN
- Twin LED electronic control
- Two Cooling Systems
- Super Cooling: automatic deactivation
- Optical and acoustic door open warning system
- Optical and acoustic warning system for malfunction of freezer compartment

Fridge Compartment

- Multi Airflow-System
- 5 safety glass shelves of which 3 are height adjustable
- Bottle storage: Bottle grid
- Bottle cooler accessory
- 3 door bins, thereof 1 dairy compartment and 1 door bin(s) high
- Dairy compartment
- 1 door bin(s) high, 2 door bin(s) small

Freshness System

- 1 hyperFresh #0°C# box - fish and meat stay fresh for longer.
- 1 hyperFresh box with adjustable humidity - keeps fruit and vegetables fresh for longer.

Freezer Section

- Freezer Capacity: 103 l
- Freezing capacity: 10 kg/24 h
- Storage time in power failure: 15 h
- 3 transparent freezer drawers

Dimensions

- Appliance Dimensions (H x W x D): 203 cm x 60 cm x 66.5 cm

Technical Information

- Door right hinged, reversible
- Height adjustable front feet
- Nominal voltage: 220 - 240 V

Accessories

- egg tray
- ice cube tray

- egg tray
- ice cube tray

Country Specific Options

- Based on the results of the standard 24-hour test. Actual consumption depends on usage/position of the appliance.

Environment and Safety

Installation

General Information

- freezerLight

iQ500, free-standing fridge-freezer
with freezer at bottom, 203 x 60 cm,
Black stainless steel
KG39NAXCF

Dimensioned drawings

Measurements in mm

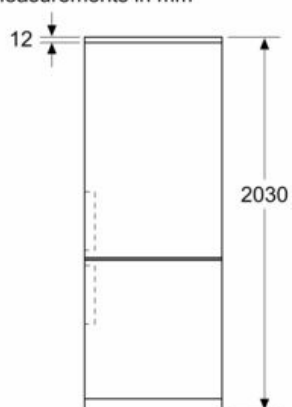

Measurements in mm

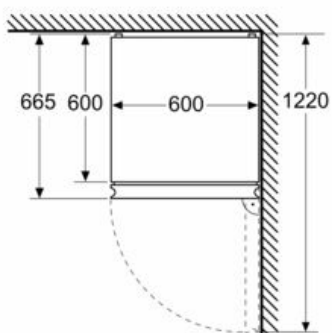

Measurements in mm

