

iQ500, Induction hob with integrated ventilation system, 70 cm, surface mount without frame ED711FQ15E

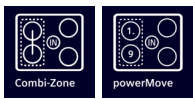
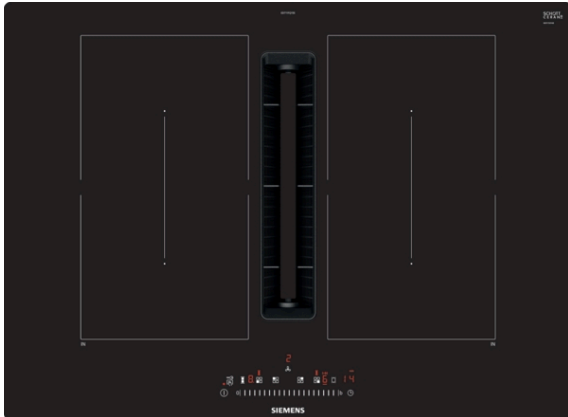

Design hob with a fully integrated, totally flush air-inlet.

- ✓ combiZone – Connect two induction zones together for large cookware.
- ✓ Allows to control the temperature by entering it directly or by moving the slider with a single finger - touchSlider Control.
- ✓ The inductionAir Plus guarantees minimal noise without compromising
 - ✓ suction power.
 - ✓ Easy cleaning – Minimal cleaning effort for your built-in
 - ✓ extractor.
- ✓ For convenient cooking thanks to preset power levels - powerMove.

Features

Technical Data

Product name/family : Cooking zone ceramic
 Construction type : Built-in
 Energy input : Electric
 Min. required niche size for installation (HxWxD) : 223 x 560-560 x 490-490 mm
 Width of the appliance : 710 mm
 Dimensions : 223 x 710 x 522 mm
 Dimensions of the packed product (HxWxD) : 430 x 950 x 660 mm
 Net weight : 23.6 kg
 Gross weight : 29.9 kg
 Residual heat indicator : yes
 Location of control panel : Hob front
 Basic surface material : Ceramic
 Color of surface : Black
 Length electrical supply cord : 110 cm
 Sealed Burners : No
 Boost function for pots : All cooking zones
 Power of 2nd heating element (kW) : 3.6 kW
 Number of speed settings : 9-stage + 2 intensive
 Maximum output air extraction : 500 m³/h
 Boost position output recirculating : 595.0 m³/h
 Maximum output recirculating air : 487 m³/h
 Boost position air extraction : 622 m³/h
 Noise level : 69 dB(A) re 1 pW
 Odour filter : No
 Operating Mode : Convertible
 Delay Shut off modes : 30 min
 Voltage : 220-240/380-415 V
 Frequency : 50-60 Hz
 Main colour of product : Black
 Length electrical supply cord : 110 cm
 Min. required niche size for installation (HxWxD) : 223 x 560-560 x 490-490 mm
 Dimensions : 223 x 710 x 522 mm
 Dimensions of the packed product (HxWxD) : 430 x 950 x 660 mm
 Net weight : 23.6 kg
 Gross weight : 29.9 kg

Optional accessories

HZ9VRCR0 : cleanAir recirculation replenishment fil , HZ9VEDU0 : Acoustics Filter , HZ9VDSS2 : Flexibel connecting piece DN 150 flat , HZ9VDS51 : Connector sleeve (female) , HZ9VDSM2 : Straight tube 1000mm , HZ9VDSM1 : Straight tube 500mm , HZ9VDSI1 : 90° Adapter round-flat , HZ9VDSIO : Adapter round-flat , HZ9VDSB4 : 90° flat duct S vertical , HZ9VDSB3 : 90° flat duct M vertical , HZ9VDSB2 : 90° flat duct L vertical , HZ9VDSB1 : 90° flat duct bend horizontal , HZ9VDKR1 : Recirculation kit S and L-bow (60cm) , HZ9VDKR0 : Recirculation kit 2 L-bow (70cm) , HZ9SE060 : 6 pieces Set , HZ9SE040 : 4 pieces Set , HZ9SE030 : Set of 2 pots and 1 pan



iQ500, Induction hob with integrated ventilation system, 70 cm, surface mount without frame ED711FQ15E

Features

- 70 cm: space for 4 pots or pans.

Flexibility of cooking zones

- 2 combiZones
- : use bigger cookware by connecting two classic cooking zones into one large zone.
- Cooking zone front left: 190 mm, 210 mm, 2.2 KW (max. power 3.7 KW)
- Cooking zone rear left: 190 mm, 210 mm, 2.2 KW (max. power 3.7 KW)
- Cooking zone rear right: 190 mm, 210 mm, 2.2 KW (max power 3.7 KW)
- Cooking zone front right: 190 mm, 210 mm, 2.2 KW (max. power 3.7 KW)

Usage convenience

- touchSlider: directly control the power with the imprinted touch bar.
- 17 power levels: precisely adapt the heat with 17 power levels (9 main levels and 8 intermediate levels).
- Switch off timer for every cooking zone
- : switches off the cooking zone at the end of the time set (e.g. for boiled eggs).
- Count-down timer
- : an alarm sounds at the end of the time set (e.g. for pasta).

Time saving & efficiency

- powerBoost for all zones: boil water more quickly thanks to 50% more energy than at the highest standard level.
- powerMove (2 levels): increase or decrease the power level simply by moving the pot forwards or backwards.
- quickStart Function: when switching on, the hob automatically selects the cooking zone with cookware (placed in off-mode).
- reStart Function: in case of unintentional switch-off, restore all previous settings by switching on the hob again within 4 seconds.

Design

- Frameless: classy, slightly raised installation without metal trim

Safety

- Residual heat indicator (2 stage): indicates which cooking zones are still hot or warm.
- Childproof lock: prevent unintended activation of the hob.
- Wipe protection function: wipe overboiled liquids without unintentionally changing settings (blocking all touch buttons for 30 seconds).
- Main Switch: switch off all cooking zones at the touch of a button.
- Safety switch-off: for safety reasons, heating stops after a preset time without interaction (customizable).
- Energy consumption display: shows the electricity consumption of the last cooking process.

Installation

- Dimensions of the product (HxWxD mm): 223 x 710 x 522
- Required niche size for installation (HxWxD mm) : 223 x 560 x (490 - 490)
- Min. worktop thickness: 16 mm
- Connected load: 7400 W
- powerManagement function: limit the maximum power if needed (depends on fuse protection of electric installation).

Accessories

- N**0154, N**0155 included
- Installation into 60 cm floor cupboard possible

Integrated ventilation downdraft system

- Induction cooktop with fully integrated high-performance downdraft extractor.
- Suitable for ducted or recirculated extraction configuration (incl. differentiated software modes). Installation accessories for unducted recirculation, among these four cleanAir Plus odour filters and a telescopic slider element, are included in the cooktop. Accessories for other installation options are available, details in the planning notes.
- Aesthetically integrated fully flush air intake design with floating, heat resistant glass ceramics element for free movement and placement of cookware.
- Ventilation system with 9 electronically controlled fan power levels and 2 Boost-/Intensive fan power levels (with automatic revert) via touchSlider user interface:
 - - Automatic switch-on of ventilation system when a cooking zone is used.
 - - Automatic delayed shut-off after cooking to erase residual odors after cooking (in specific ultra low-noise fan level, 12min in ducted extraction, 30min in recirculated extraction, can be shut-off manually).
 - - Fully manual control via touchSlider.
- High-performance, low-noise blower with energy-efficient BLDC-technology. High extraction rates at very low noises with pleasant noise frequencies through psycho-acoustically and aerodynamically optimized interior with enclosed, non-visible blower. Highly pressuredrop resistant even with longer and more complex ductings.
- Easy-to-detach and easy-to-clean grease filter and liquid collector unit:
 - - Convenient one-hand removal of unit via floating glass ceramics handle.
 - - Integrated, large-scale, high performance stainless-steel grease filters with 12 filtration layers and one black top layer for enhanced aesthetical integration. Grease filtration efficiency of 94 %.
 - - All parts of the unit are easy-to-clean, fully dishwasher safe and heat resistant.
 - - (Upper) Liquid collector unit with 200ml of capacity for standard accidental spillages or cooking condensate.
 - - Powerful drainage system for spillages that exceed 200ml of liquids.
 - - Liquid safety collector with additional capacity of 700ml for more severe accidental situations. Dishwasher safe. Easily accessible and detachable from below.
 - - Overall capturing capacity of 900ml (200ml + 700ml).
 - - Watertight blower system.
- Ventilation system performance:
 - - Extraction performance in ducted extraction (according to EN 61591): min. normal setting 154 m³/h, max. normal setting 500 m³/h, max. Boost-/Intensive setting 622 m³/h.

iQ500, Induction hob with integrated ventilation system, 70 cm, surface mount without frame ED711FQ15E

Features

- Extraction performance in recirculated extraction (according to EN 61591): min. normal setting 117 m³/h , max. normal setting 487 m³/h , max. Boost-/Intensive setting 595 m³/h.
 - Noise level in ducted extraction (Sound power level according to EN 60704-3): min. normal setting 42 dB re 1 pW, max. normal setting 69 dB re 1 pW, max. Boost-/Intensive setting 74 dB re 1 pW.
 - Noise level in recirculated extraction (Sound power level according to EN 60704-3.): min. normal setting 41 dB re 1 pW, max. normal setting 68 dB re 1 pW, max. Boost-/Intensive setting 72 dB re 1 pW.
 - Grease filter efficiency (according to EN 61591) 94 %.
 - Consumption data and energy efficiency (according to Regulation (EU) No 65/2014):
 - Energy Efficiency Class: B (at a range of energy efficiency classes from A+++ to D).
 - Fluid Dynamic Efficiency: A .
 - Average energy consumption: 57 .
 - Grease filtration efficiency class: B .
 - Noise min. normal setting & max. normal setting: 42 dB & 69 dB .
 - For recirculation configuration: 2 x 2 battery of directly integrated, high-performance cleanAir Plus odour filters.
 - Optimized odor reduction performance for cooking applications with complex odor molecules (e.g. fish).
 - Large scale filter surface with high odor reduction capabilities.
 - Anti-pollen functionality: The filter retains an extremely high amount of airborne pollen and deactivates allergens which are retained by the filter.
 - Lifetime of 6-12 months (non-regenerative).
 - Low-noise filters with optimized psycho-acoustics.
 - Easy-to-access and easy-to-remove from above.
 - Replenishment cleanAir Plus odour filter set HZ9VRCR1.
 - For ducted extraction configuration: 2 x 2 Battery of directly integrated, high-performance low-noise acoustic filters for significantly lower noise and improved psycho-acoustics.
- Planning notes**
- Suitable for ducted or recirculated extraction installations in 4 different options (unducted, partly and fully ducted recirculation or ducted extraction). Installation accessories for unducted recirculation, among these four cleanAir Plus odour filters and a telescopic slider element, are included in the cooktop. The included accessories allow easy and quick installations and can be planned in all worktop depths ≥ 60 cm. For other types of installation, one of the following accessory kits is recommended:
 - HZ9VDKR1 for partly-ducted recirculation in worktops of ≥ 60 cm depth with max. worktop height of 960 mm. HZ9VDKR0 for partly-ducted recirculation in worktops of ≥ 70 cm depth with max. worktop height of 960 mm.
 - HZ9VDKE1 as starter kit for ducted extraction in worktops of ≥ 60 cm depth.
 - To complete the fully ducted extraction or to do any other individual recirculation planning different ducting accessories are available.
 - Planning suggestions:
 - Installation is possible in island as well as wall oriented configurations.
 - The product and its accessories comply with the Needle Flame Test (according to IEC 60695-11-5) and the B1/B2 building material class (according to DIN 4102-1).
 - The max. immersion depth is 223 mm below worktop surface.
 - The appliance must be freely accessible from below (i.e. for accessing the lower liquid safety collector).
 - No false floor is necessary below the cooktop with integrated downdraft ventilation system. The drawers and/or shelves in the floor unit must be removable. The backpanel of the floor unit can be kept - only a cut-out for the air outlet is needed (position and size can be taken from the installation instructions).
 - An installation with unducted recirculation requires a vertical aperture of min. 25mm behind the backpanel of the furniture. Suggested for ideal performance are 50mm.
 - The minimum worktop thickness is 16 mm for top mounted and flush installed appliances with the standard installation system. Installation in even thinner worktops is also possible with the spare part: content 626792.
 - The overall appliance weight is 26kg - the bearing capacity and stability, in the case of very thin worktops in particular, must be supported using suitable substructures. The overall appliance weight and the worktop manufacturer's structural integrity specifications are to be taken into account.
 - For partly ducted and unducted recirculation extraction installations, a return-flow aperture of ≥ 400 cm² is to be respected in the plinth area. The aperture can be realized via outlet grids, lamella grids or subtly shortened plinths depending on the assortment of the kitchen furniture manufacturer.
 - The air outlet on the backside of the appliance can directly be accessed with a male flat duct element (DN 150).
 - The pressuredrop resistant blower allows longer and more complex ductings up to 8m with three 90° bows while keeping sufficient performance.
 - When installing an venting cooktop with ducted extraction and a chimney-vented fireplace, the power supply line of the appliance needs a suitable safety switch. This is not required for configurations in recirculated extraction.
 - In ducted extraction configuration a one-way flap (or backflow trap) with a maximum opening pressure of 65Pa should be installed.

iQ500, Induction hob with integrated ventilation system, 70 cm, surface mount without frame ED711FQ15E

Dimensioned drawings

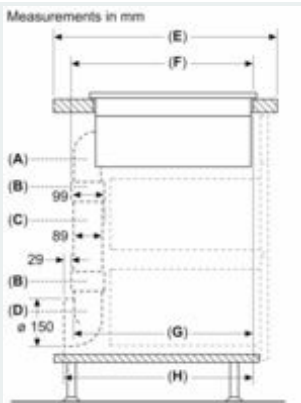

A	E	F	G	H
S-size	≥ 600	547	545	579
M-size	≥ 650	574	569	603

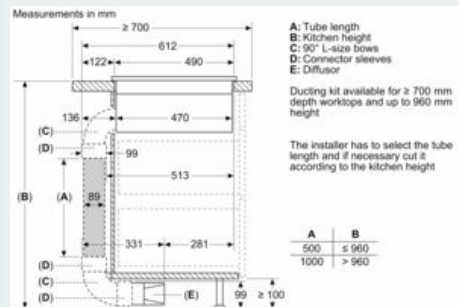
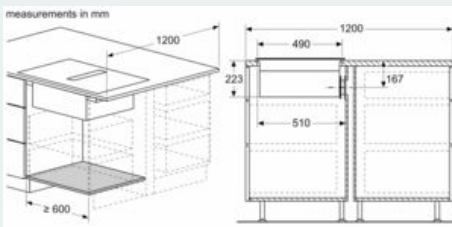
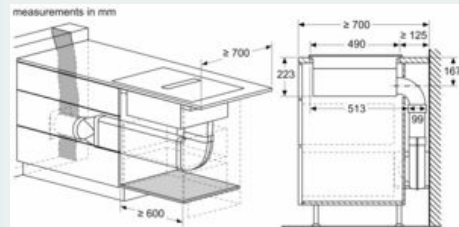
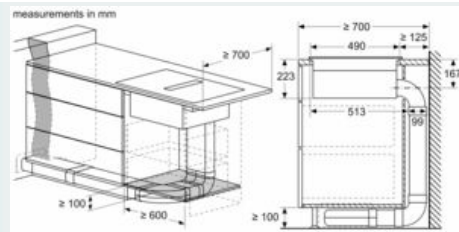
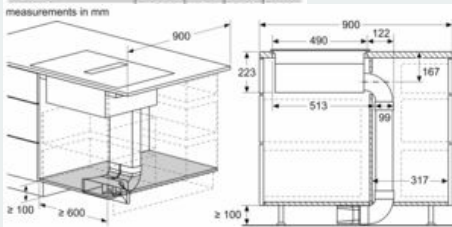

A: Tube length
B: Kitchen height
C: 30° L-size boxes
D: Connector sleeves
E: Diffuser

Ducting kit available for ≥ 700 mm depth worktops and up to 960 mm height

The installer has to select the tube length and if necessary cut it according to the kitchen height

A	B
500	≤ 960
1000	> 960

iQ500, Induction hob with integrated ventilation system, 70 cm, surface mount without frame
ED711FQ15E

Dimensioned drawings

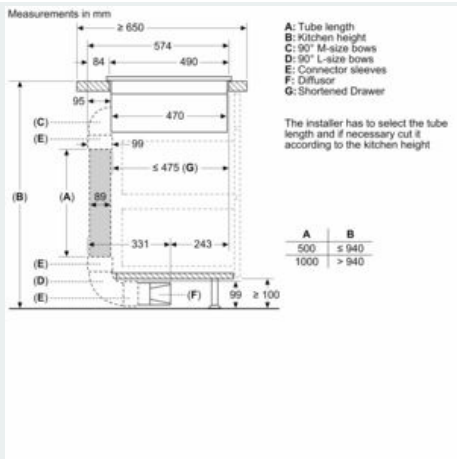

measurements in mm
Front view - unit cut-out
for unducted recirculation

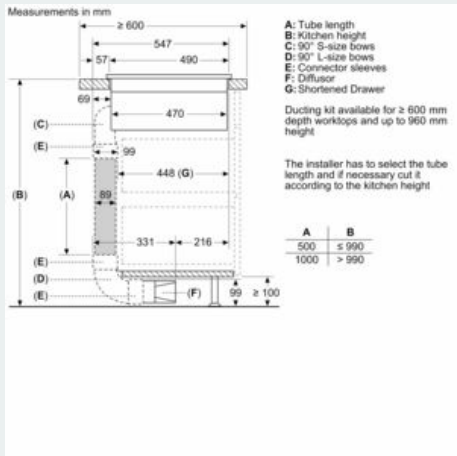
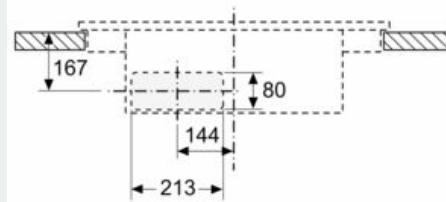

measurements in mm
Front view

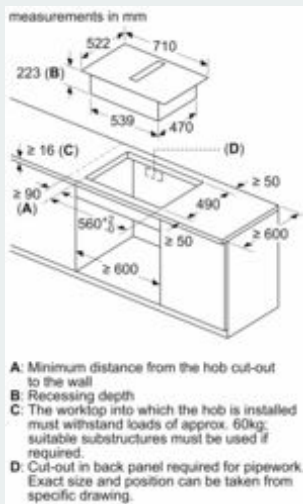
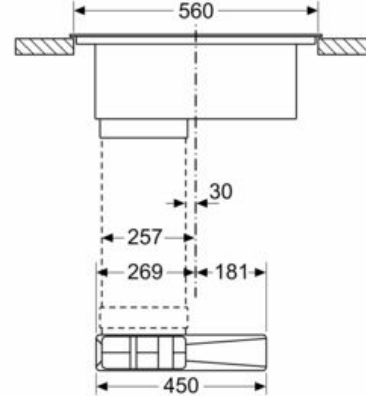

measurements in mm
Front view

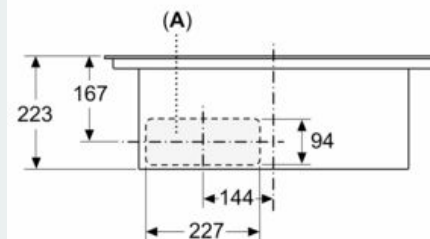

A: Connected directly at the rear

iQ500, Induction hob with integrated ventilation system, 70 cm, surface mount without frame
ED711FQ15E

Dimensioned drawings

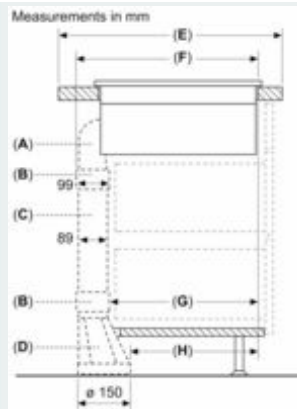
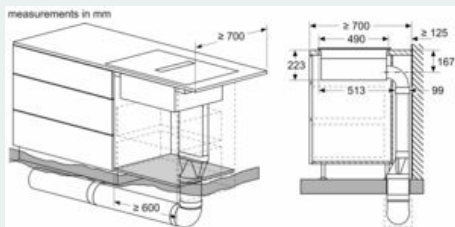
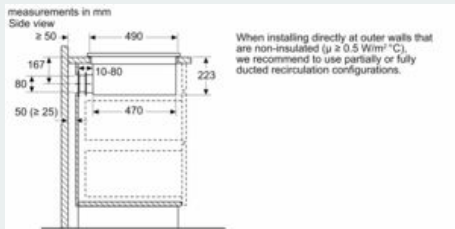
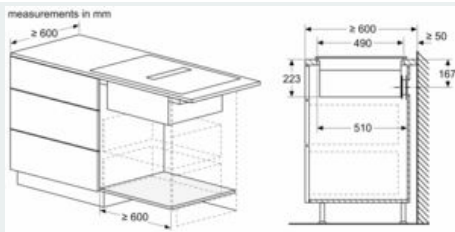

A	E	F	G	H
S-size	≥ 600	547	451	389
M-size	≥ 650	574	475	413
L-size	≥ 700	612	515	453

- A: 90° Bow
- B: Connector sleeves
- C: Straight tube
- D: Straight adapter round flat